

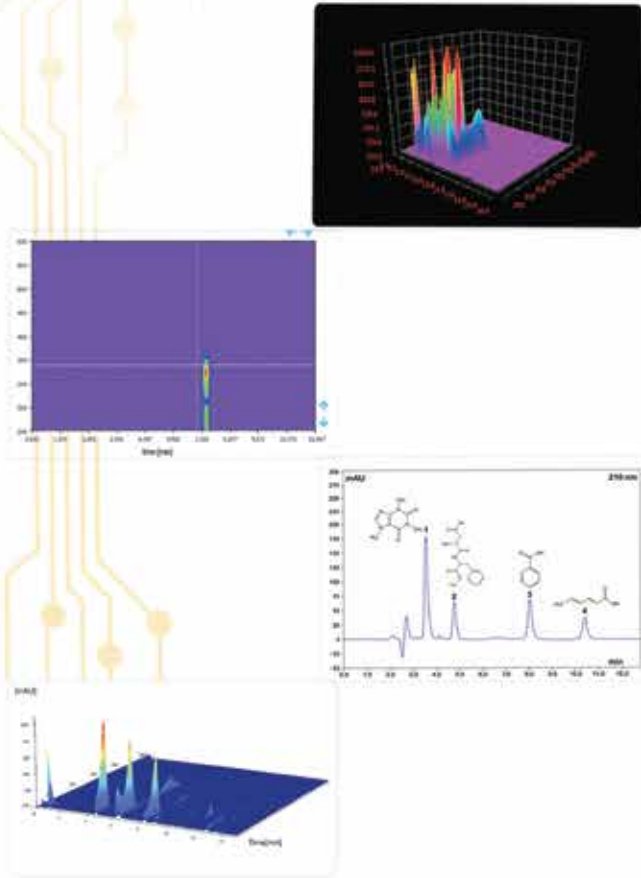

Multiplelabs[™]
Turnkey Laboratories Solutions



Analytical[®]
Technologies Limited



iUHPLC 3000 PLUS

**INTELLIGENT ULTRA HIGH PRESSURE
LIQUID CHROMATOGRAPHY**

EPC / PRODUCTS / APPLICATION / SOFTWARE / ACCESSORIES / CONSUMABLES / SERVICES

Analytical Technologies Limited

An ISO 9001 Certified Company

www.analyticalgroup.net

Liquid Chromatography Family



Professional service
Modularized design
Multi-channel pumps
Alternative injection modes
Various detectors
Custom combination

Flexible configuration
9000PSI working pressure
2.5AU Linearity range
100Hz Sampling rate
Rapid analysis achievable
More efficient, less consume

iUHPLC



Excellent Performance

Instrument installation & various training courses
Application & regulatory compliance service
Remote diagnose & prompt response
Preventive maintenance & service plans
Proactive and comprehensive service

ELSD



RI Detector



Typical Configuration



Isocratic System with Manual Injector

This isocratic system could deliver one type of mobile phase. By combining the best performance cost ratio, system stability and maintenance simplicity, this system is an ideal solution for routine QA/QC analysis and GPC/SEC application. It can also be simply upgraded into gradient system with autosampler to boost your productivity.

Quaternary System with Autosampler 3000 Plus

Quaternary system possesses the advantage of great flexibility, and it can further be automatized by combining our autosampler. This combination could fulfil the complex requirements from pharmacy, agricultural & farming fields. With the control from ALT Chromatography workstation, it realized full automatic analysis, report, system flush, shut down and then raised up the efficiency. environmental, food safety, petrochemical engineering,



Binary System with Autosampler

With excellent gradient precision & optimized delay volume, this binary system plus autosampler is ideal for complex gradient application or be used in combination with mass spectrometry. With the convenience of autosampler and various detector, the user could easily get more data.





3000 Plus High Pressure Pump

Performance Highlights

High Precision

3000 plus serial high pressure pump could reach 9000psi (62Mpa) working pressure with the flow rate up to 10mL/min. This high performance extend the application field from normal HPLC to Fast HPLC. With the help of 100Hz detecting and high precision sampling, you can take advantage of small piratical size column and reduce solvent consumption.

Precise Flow Rate & Gradient

3000 plus serial high pressure injection pump could monitor the pressure status by its digital signal processor and adjust the motor operation status based on working parameters and solvent type. This real time feedback mechanism plus the high performance proportional valve realized the steady flow output as well as precise Quaternary low pressure gradient pump with dual reciprocating pistons in series/parallel double plunger.

Stable Pressure

3000 plus serial high pressure pump's pressure pulsation could be controlled under 10psi with best qualitative repeatability based on it state of art patent design, precise engineering and strict quality control..

Column: back pressure tube (1000PSI)
Mobile Phase A: 1% isopropanol aqueous solution
Mobile Phase B: 0.2% acetone/1% isopropanol aqueous solution
Flow rate: 1.0ml/min
Temperature: room temperature

Chromatographic column: Manufacturer A C18(250 mm*4.6mm* 5µm)
Mobile Phase: 0.05mol/L phosphate buffer(pH = 3.5)/MeOH/acetonitrile (50/35/15)
Flow rate: 1.0ml/min
Temperature: 40°C
Detection wavelength: 254nm
Injection volume: 20µL

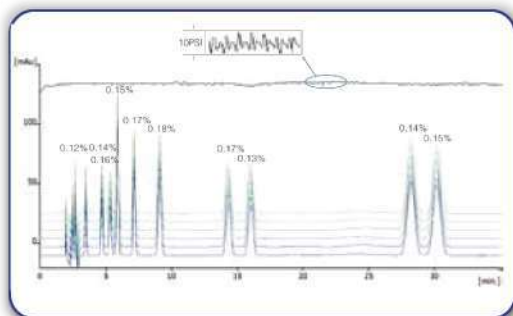
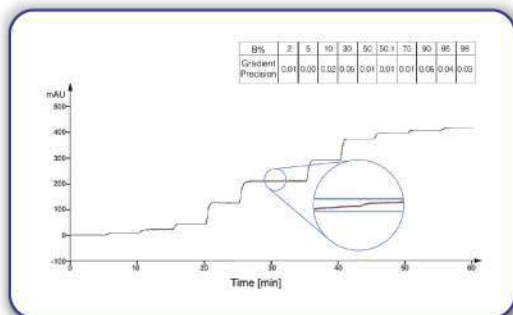
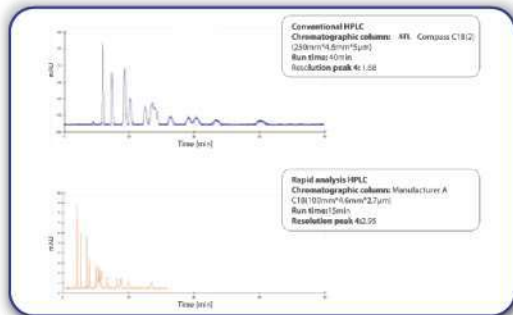
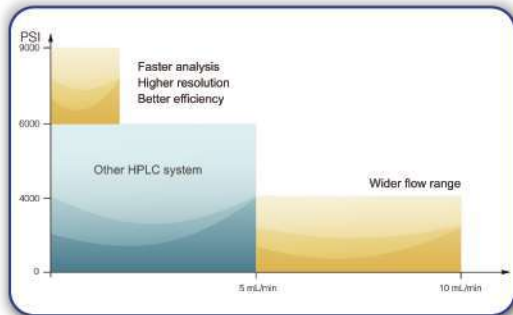

Working Principle

3000 plus serial high pressure pump provides isocratic, binary and quaternary model base on request.

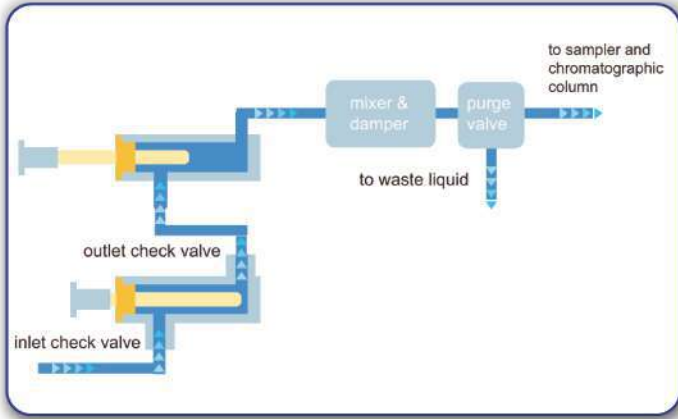

Isocratic pump for regular QA/QC usage

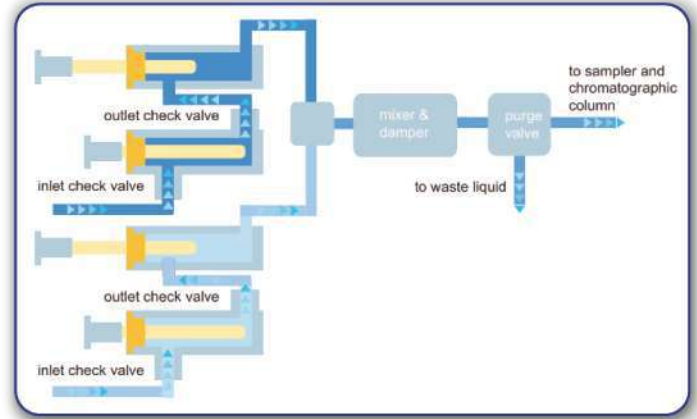

Binary pump for high-throughput & fast analysis

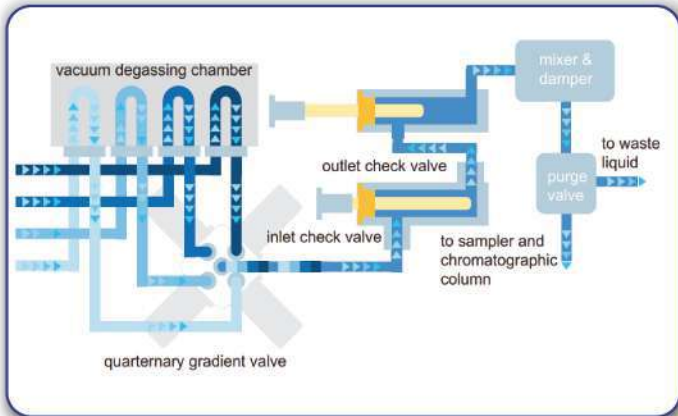

Quaternary pump for pharmaceutical, food and environmental test.

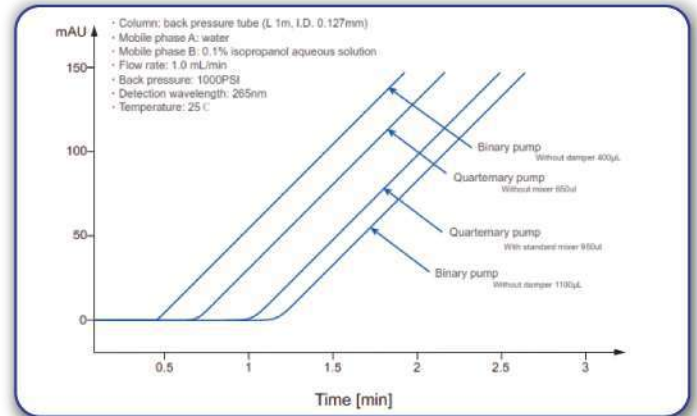

Lower delay volume enables a cleaner & faster response to the gradient changes.

Special Design

Integrated Design

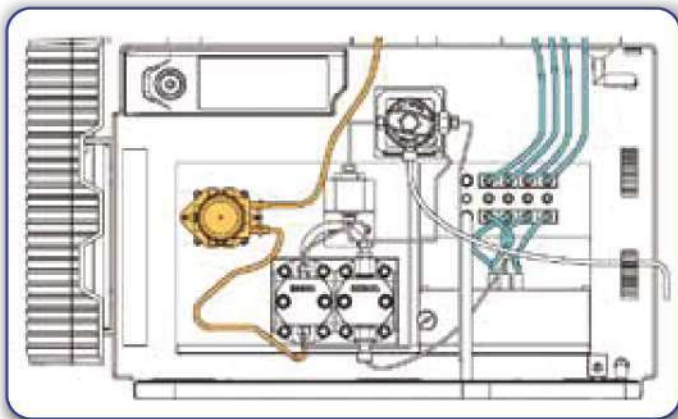

3000 plus Quaternary gradient pump combine online degasser and seal wash function. This integrated design reduce delay volume, save bench space and simplify maintenance procedure.

Built-in Seal Wash Function

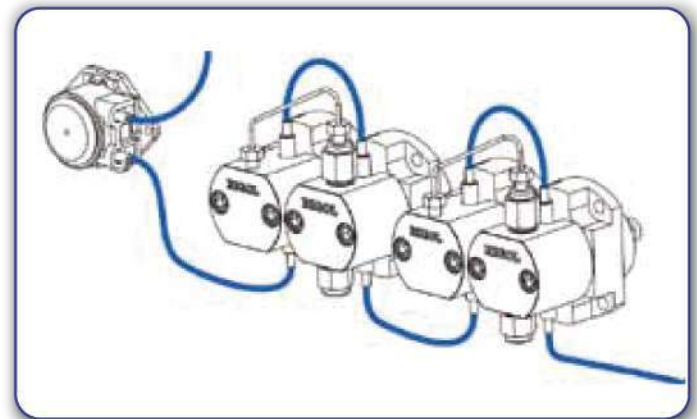

Seal wash is a standard parts in 3000 plus serial HPLC system. The part could flush the salt crystallization on the piston and extend the service life of sealing rings.



3000 Plus Autosampler

Performance Highlights

High Precision

3000plus autosampler delivers high injection accuracy of 0.3% RSD, thanks to its high precision machining parts and advanced control algorithm. It also employ a design of changeable sampling loop, which extend linearity range and meet the need of more applications.

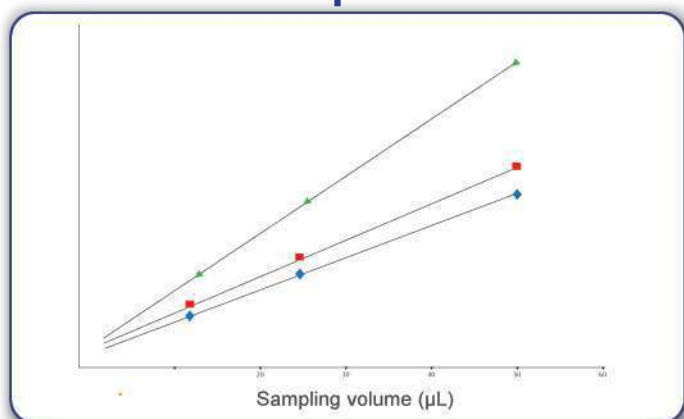

sampling volume from 2.5 to 50µL, correlation coefficients of the 3 compounds are all 0.9999

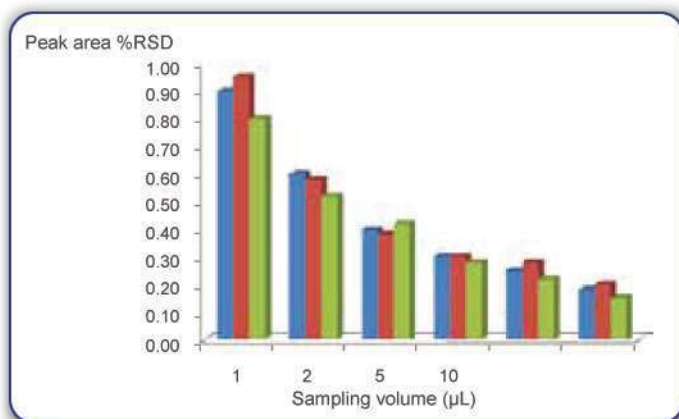

Peak-area repeatability of 3 compounds with different sampling volume (RSD%)(n=6)

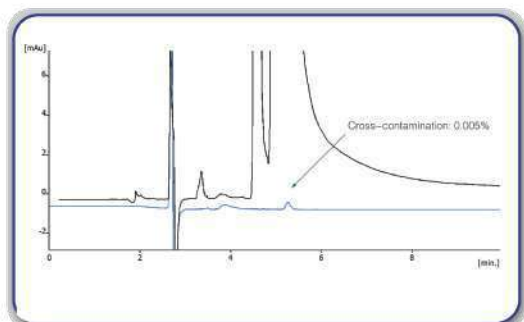

Low Cross Contamination

The special design of needle washing assembly could clean interior and outside of the sampling needle separately, combining the patented sampling needle design and extra precision inner and outer polishing technology, it could reduce the carryover of sample and avoid cross contamination.

Chromatographic column: (250 mm x4.6mm x 5µm) MeOH/Water(90/10) 10µL
Cross-contamination: 0.005%(based on naphthalene-methanol solution)

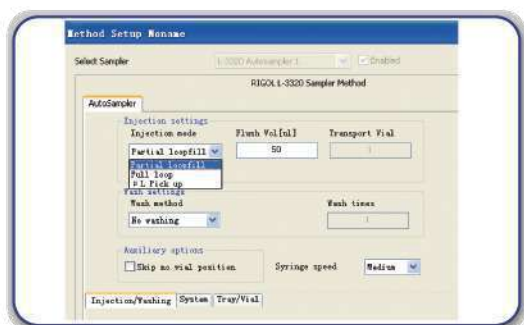

Multi Injection Mode

3000plus support three sampling mode including full loop, partial loop and micro pick-up injection for different requires. It could be easily choice in the method editor without hardware replacement.

In the Method Setup interface you can simply choose to click a different injection mode, then the replacement is completed.



Working Principle

Three Sampling Mode

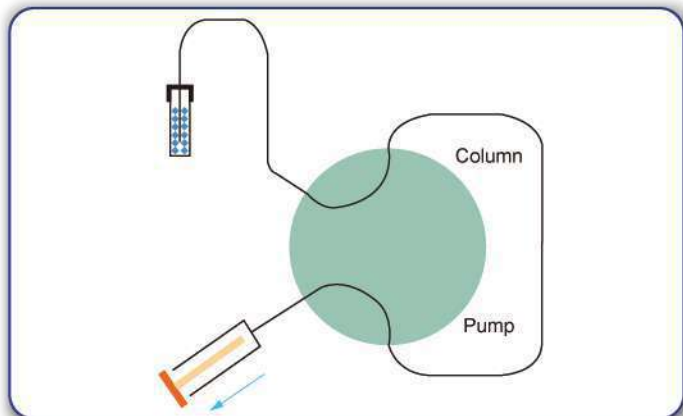

3000 plus AutoSampler adopt suction sampling principle with simple & reliable structure to reduce delay volume, it divided into triple specific sampling modes.

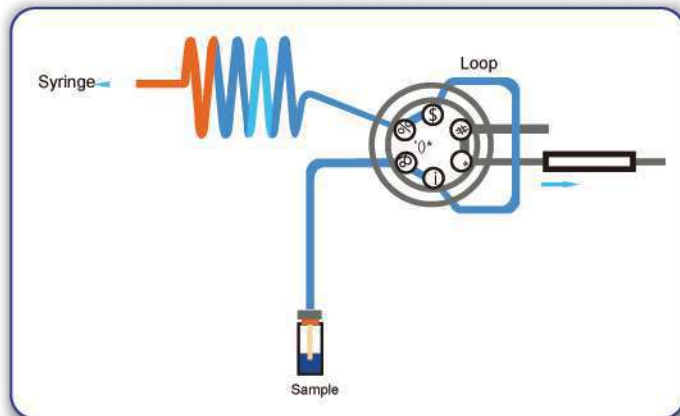

Full loop injection possess best sampling precision, with the support of changeable sampling loop, this mode fulfill most requirements.

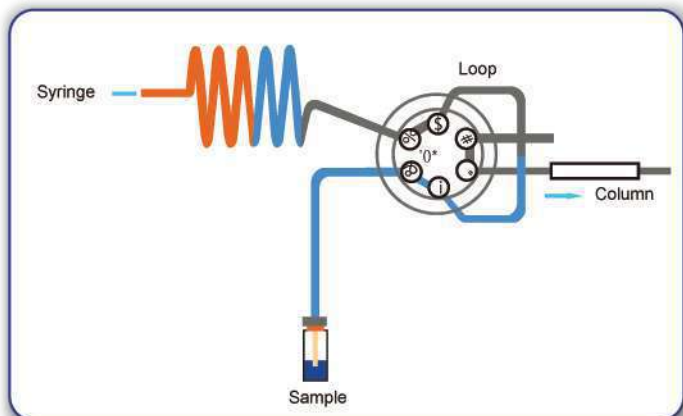

Partial injection has the best and most flexible performance, you can set the injection volume to match the application.

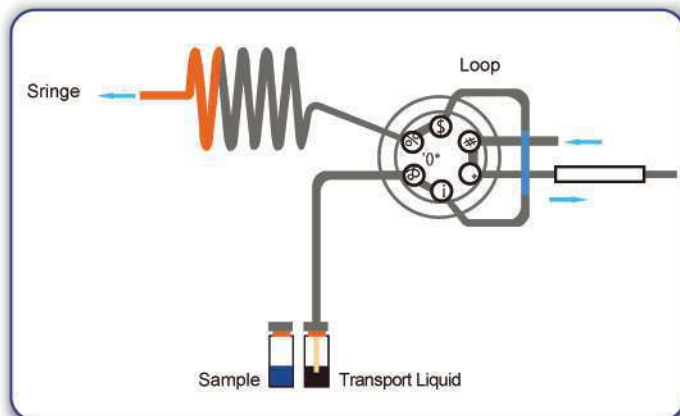

Micro Pick-up mode was suitable for small quantity and precious sample, the injector will only pick up the setting volume sample and use the suitable

Special Design

Build-in Needle Wash Assembly

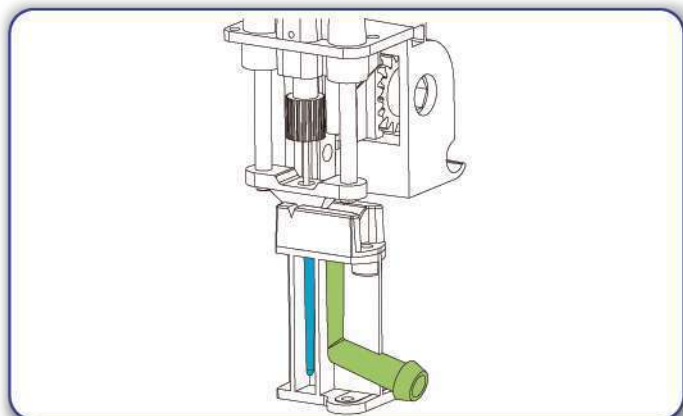

The build-in needle wash assembly has two washing positions for inter and outer needle wash separately, this double wash mechanism reduced the carryover significantly.

Front Access to Maintenance Parts

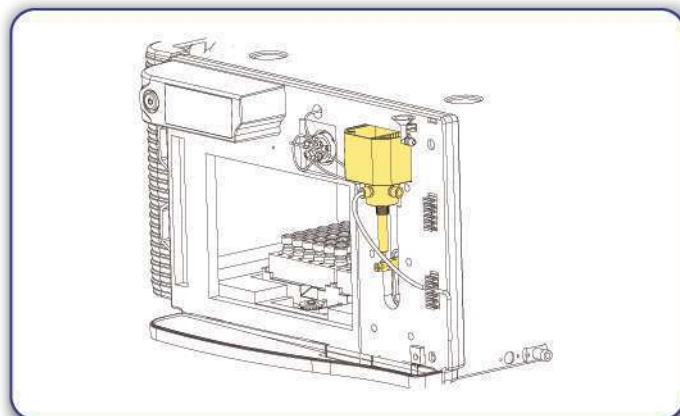

All maintenance parts could be reached on the front side, which simplify the service procedure and lower maintenance cost.



3000 Plus UV-VIS Detector

Performance Highlights

High Sampling Rate

As support by unique high speed signal processing technology, 3000plus UV - VIS detector realized 100 Hz sampling rate, which make the detection of narrow peak with width lower than 5s possible. This high sampling rate also helps to record the chromatography peak accurately and get the best resolution.



Proprietary optical design for improved signal to noise ratio.

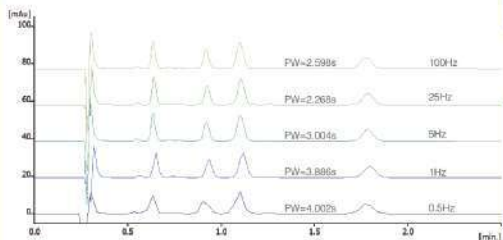

100Hz data sampling rate means that detection of peaks sharper than 5s wide is possible with excellent separation resolution.

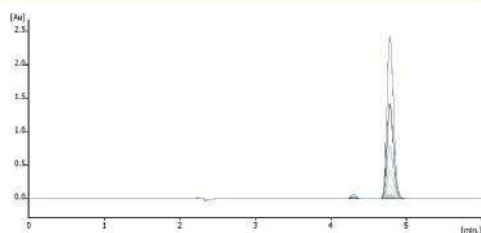

Wider Linearity Range

Adopt unique light path design, multi color optical filter and high quality grating, the detector realized more lower stray light, and extend the linearity range to 2.5AU.

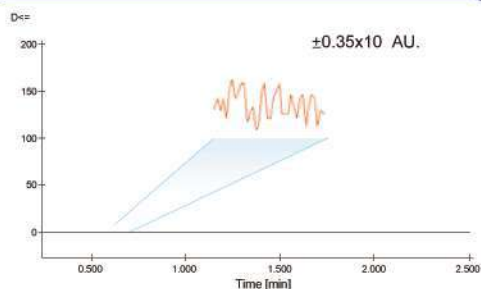

Low Noise

3000 plus have a high performance SNR by the patent electric and structure design.

Working Principle

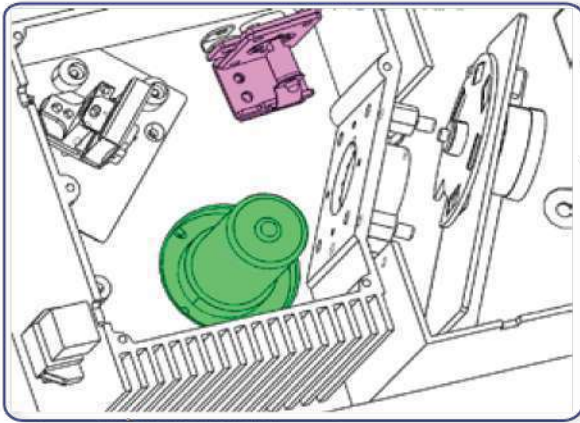

Dual Lamp Design

3000 plus UV-VIS detector employ a dual lamp design, the deuterium & tungsten lamp enable the detector to cover both UV and visible range and fulfill the visible section detection and cover more application scope.

Easy Maintenance Flow Cell

The flow cell adopt modular design, it could be taken off by only 2 screws removing, very easy to maintenance.

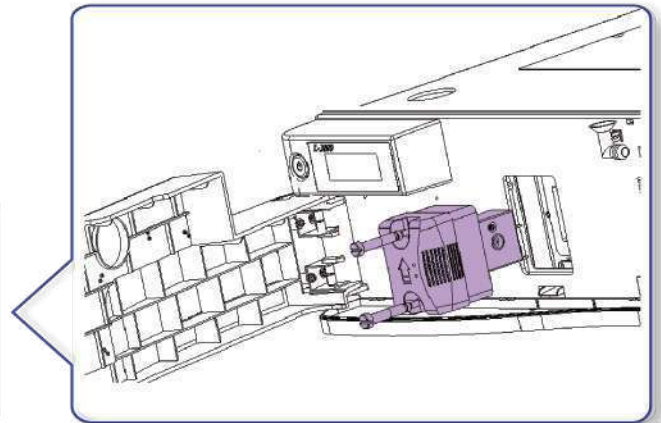

Application Notes

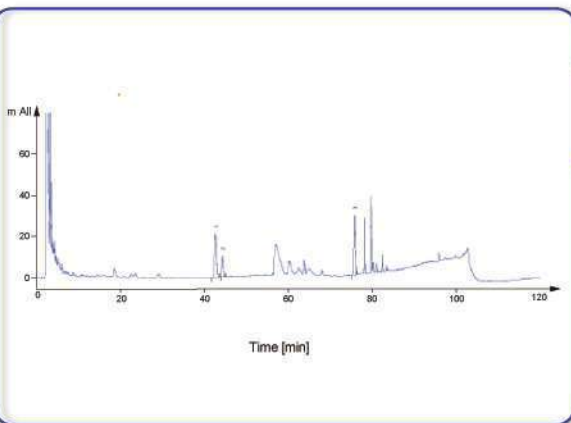

3000 plus shows great stability, especially in those applications with long run time and low detecting wavelength, this advantage can be perfectly shown by the 120min run.

Chromatographic column: ATL Compass C18(250mm*4.6mm*5 μ m)

Mobile phase: water/acetonitrile; gradient elution Column temperature: 40°C

Flow rate: 1.0mL / min Detection wavelength: 203nm Injection volume: 10 μ L

3000 plus can run wavelength program, which means switching detection wavelength during acquisition. This feature realized the programmable detection of several analytes with different chromophore.

Chromatographic column: Manufacturer AC18(100 mm*4.6mm*2.7 μ m)

Mobile phase: 20mM aqueous ammonium acetate/acetonitrile; gradient elution

Flow rate: 1.0mL / min Column temperature: 40°C

Detection wavelength: wavelength time program Injection volume: 20 μ L

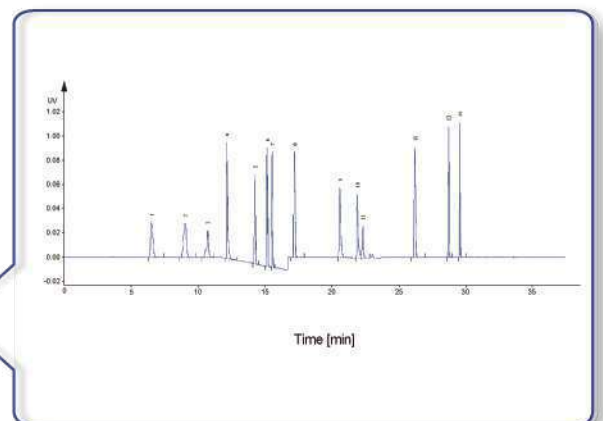



3000 Plus Diode Array Detector

Performance Highlights

High Resolution Full Spectrum Scanning

3000plus has a 1024 diode array sensor with pixel resolution of 0.6nm. Combine with high quality optical grating, it could record full high resolution spectrum while chromatogram recording.

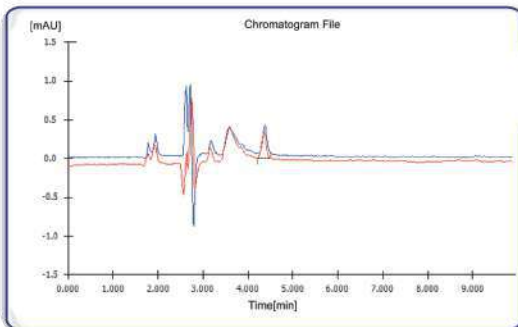
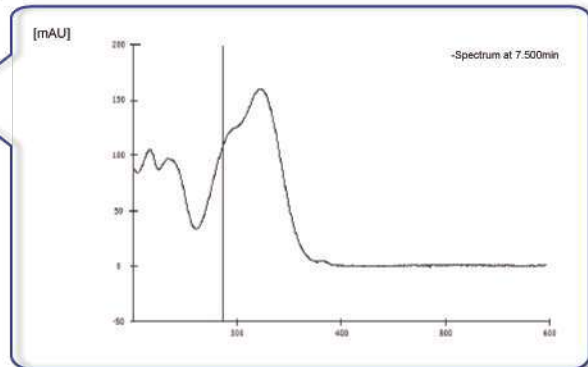
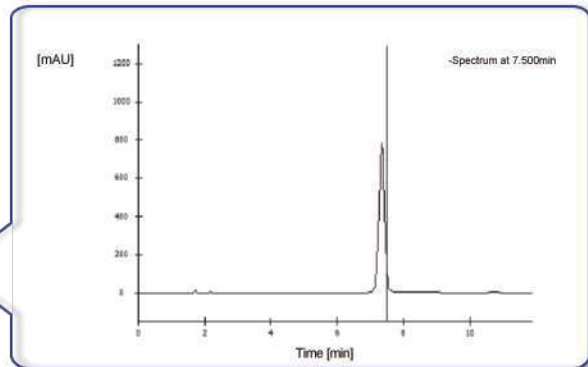
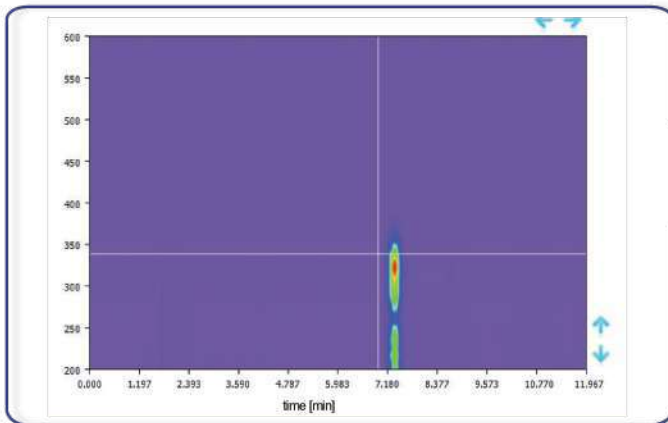

High Sensitivity

3000 plus realized $\pm 0.6 \times 10^{-5}$ AU noise level by its advanced optical and electric design, and gain more lower detection limit.

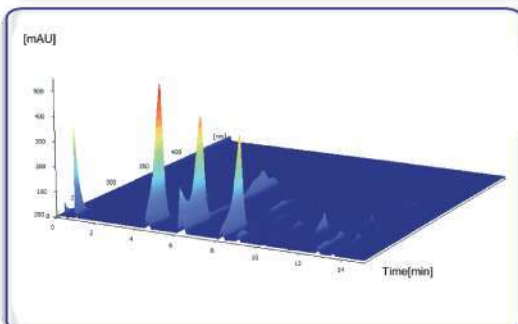

High Sampling Rate

ATL remains and advances the high sampling rate character of UV detector, and keep 100 Hz sampling rate with full spectrum scanning. Users can acquire high resolution spectrum, and also could extract chromatogram for quantitative analysis.

Working Principle

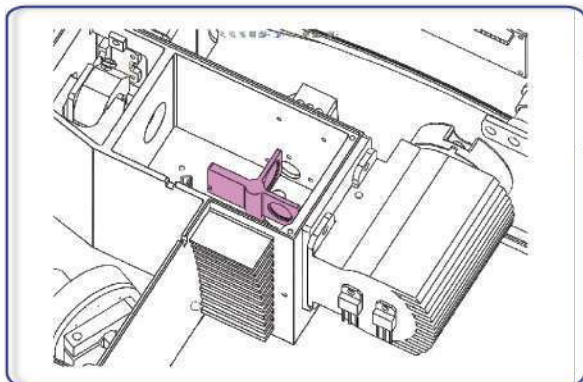

Easy Calibration Function

deuterium lamp characteristic peak and build-in holmium oxide filter. 3000 plus could realize full spectrum calibration by mercury lamp standard emission lines, and ensure the instrument stable and reliable by double inspecting the wave length accuracy

Easy Accessed Lamp

3000 plus DAD adopt light prepositioning design, and equipped with easy disassembling flow cell. Client could do the lamp replacing independently and then reduce the future maintenance cost.

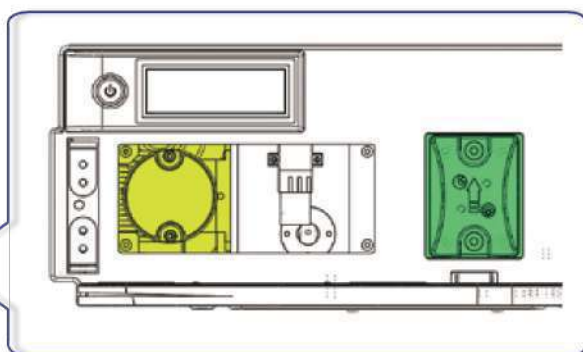

Application

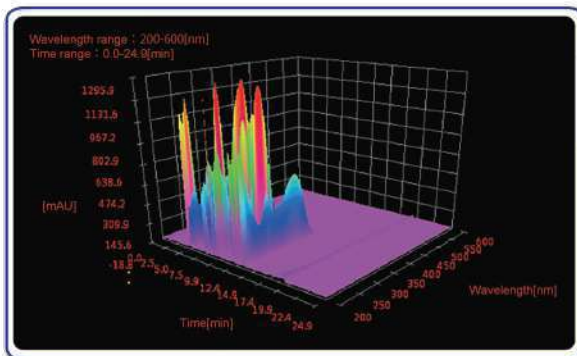

The chromophore of the eight phenols in olive oil varies a lot, those analytes must be monitored at different wavelength and the retention time is similar, those realities makes it impossible to analyse it by UV-VIS detector. DAD possess the ability of multi-wavelength detection and full spectrum acquisition, perfect for qualitative and quantitative analysis.

Chromatographic conditions
 Chromatographic column: Manufacturer AC18(100mm*4.6mm*2.6μm)
 Mobile phase: 0.2% aqueous phosphoric acid/acetonitrile; gradient elution
 Flow rate: 1.0mL / min
 Column temperature: 28°C
 Injection volume: 5μL

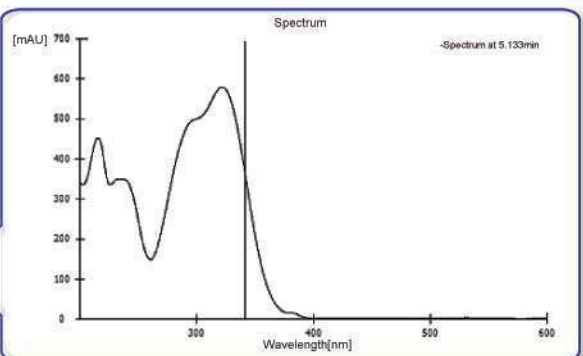
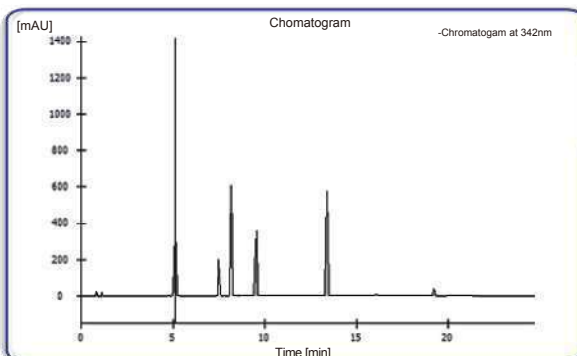
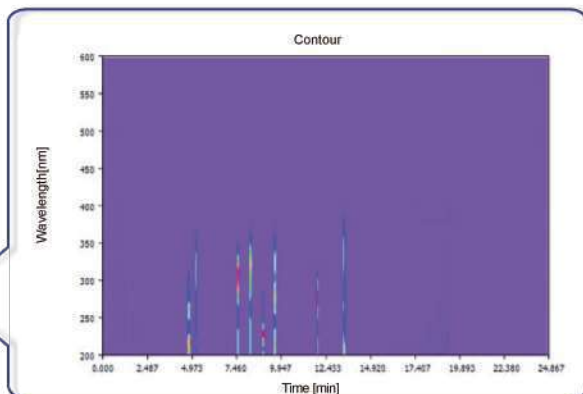



Evaporative Light Scattering Detector

Performance Highlights

Low-Temperature Evaporation

Automated Gain Adjustment (AGA)

AGA is an innovative gain control available when it is driver-controlled by software, automatically adapts the gain setting to avoid any off-scale saturation of the detector.

Easy Maintenance

A single and dedicated HPLC nebulizer and an innovative cell design minimize band broadening. This nebulizer covers the flow rate range from 100 μ L/min to 2.5mL/min and can be readily and quickly mounted and dismantled.

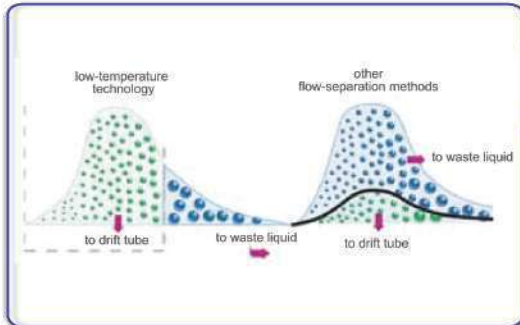

low-temperature operation (user defined from ambient 80°C) optimizes sensitivity for those analytes that are easily missed at higher evaporation temperatures typical of competing detectors.

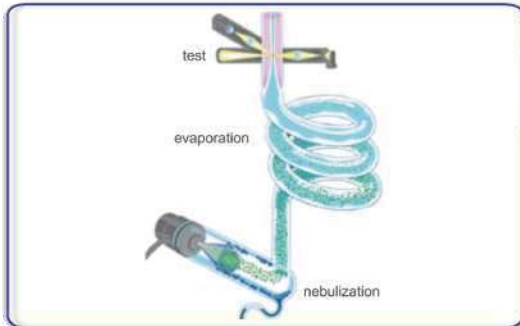

100Hz data sampling rate means that detection of peaks sharper than 5s wide is possible with excellent separation resolution.

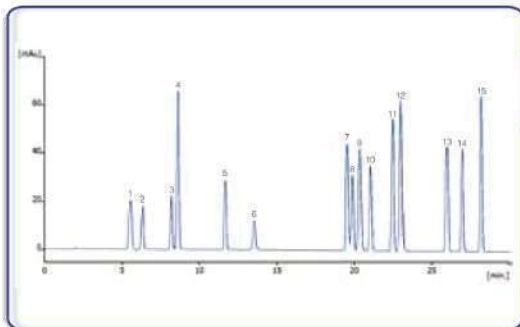

Determination of 15 underivatized amino-acids via HPLC-ELSD

Chromatographic column: ATL (250 mm x4.6mm x 5 μ m)
Mobile phase: 0.2% Heptafluorobutyric Acid /MeOH; gradient elution
Temperature of drift-tube: 40°C
Increment: 7

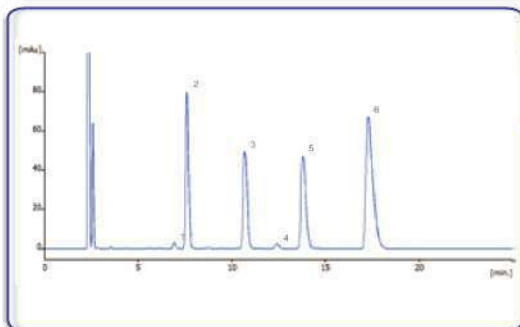

Determination of gentamycin sulfate injection via HPLC-ELSD

Chromatographic column: ATL (250 mm x4.6mm x 5 μ m)
Mobile phase: 0.2mol/L trifluoroacetic acid solution/MeOH (92/8)
Temperature of drift-tube: 50°C
Increment: 6



Performance Highlights

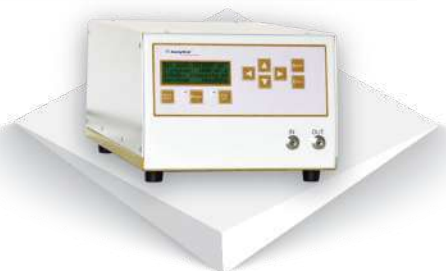

Refractive Index Detector

Broad Application

Detection is based on a universal property of all analytes and does not require the presence of a chromophoric group, electroactive group, etc.

Stable Performance

Base line will be rapidly balanced by the inner temperature control system. And prevent the influence.

Easy Operation

Preposition operation panel will help you set the instrument in several steps, and no need to revise the parameter during the operation. This will reduce the learning cost and enhance the efficiency. temperature floatation.

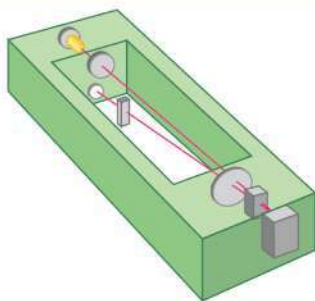

3000 Plus achieve better stability and repeatability by inner temperature control system.

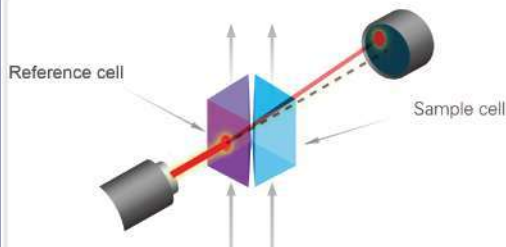

3000 Plus can detect all analytes that have different refractive coefficient in the mobile phase.

1. Mannitol
2. Sorbitol

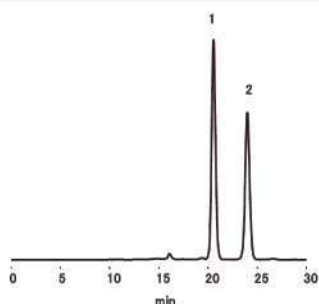

Analysis of Mannitol according to EP method

Chromatographic column: EP SC1011-7F (7.8mmI.D. x 300mm)
Mobile phase: Water
Flow rate: 0.5mL/min
Column temperature: 85°C

1. Sucrose
2. Glucose
3. Fructose
4. 5-HMF
5. Furfural

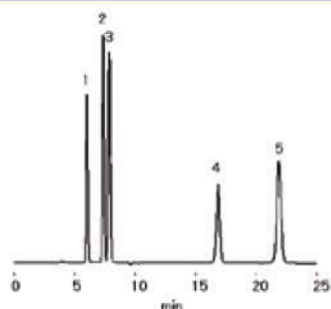

Analysis of Sugar and Furfural

Chromatographic column: SUGAR KS-801 (8.0mmI.D. x 300mm)
Mobile phase: Water
Flow rate: 1.0mL/min
Column temperature: 80°C



3000 Plus Solvent Organizer

Performance Highlights

Ultra Experience Operating

3000 Plus UHPLC system equipped with L-3100 serial solvent organizer, which could remove the bubble influence effectively, and reduce the pressure fluctuation & base line noise.

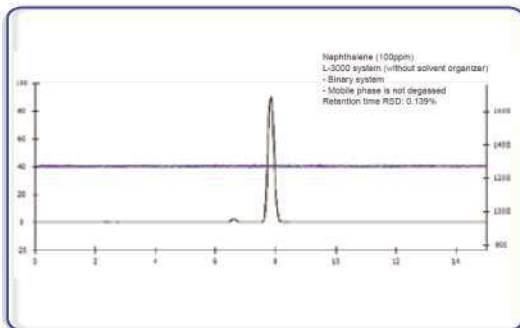

Pole Washing System

The washing system composed with solvent organizer and pump coordination, it could wash the pole and sealing ring salt crystallization and prolong the service life.

High Efficiency Degasser

3000 Plus solvent organizer equipped with 2/4-Channel degasser which will remove the remaining gas dissolution in the mobile phase, and make the pump operation more stabilized and reduce the base line noise.

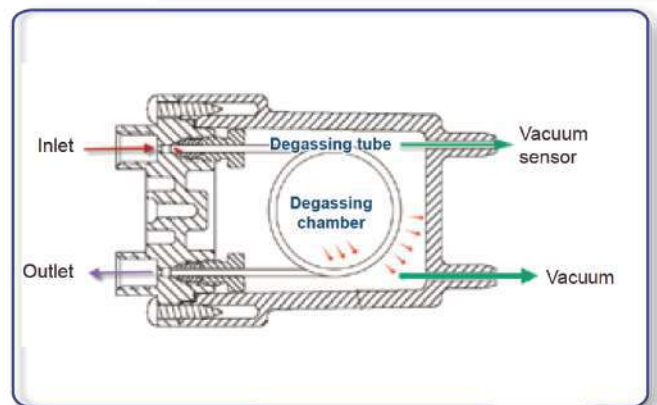
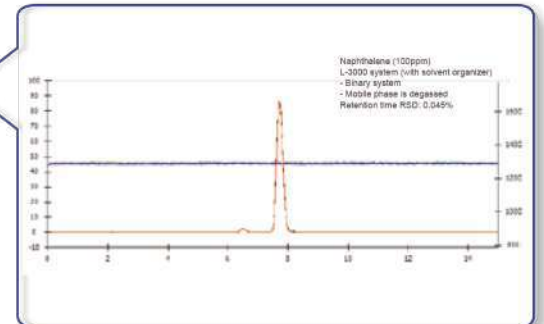

Bubbles Damages

- (1) It will lead to the big base line noise, and influence the base line till it could not be regularly works.
- (2) It might raise the problem with single direction valve, especially will cause big pressure floatation once you choice the pressure floatation control option.
- (3) Gradient mixing will generate the bubbles due to different characters of solvents. None degassing solvent provide the condition of bubbles generation.
- (4) Influence the detector operation, likes fluorescence quenching, reduce the sensitivity of FLD.

Performance Highlights



3000 Plus Column Oven

Excellent Testing Results

3000 Plus HPLC system work with 3000 Plus column oven, which could minimize the impact of environmental factors and then guarantee the superior results.

Column Advisor

The Column Advisor recommend the most appropriate column depending on the application requirements you need to consider and the column characteristic you are looking for.

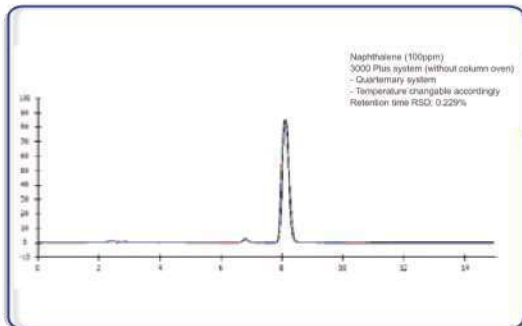

Preheating Function

Via preheating treatment, mobile phase will be reach rated temperature before coming into the column, so avoid the unbalance temperature status in the column, then avoid the influence of temperature floatation also.

Precision Temperature Control

3000 Plus utilized the semiconductor heating technology, and avoid the over shoot of temperature raising, then ensure the stable temperature raising and precision control.

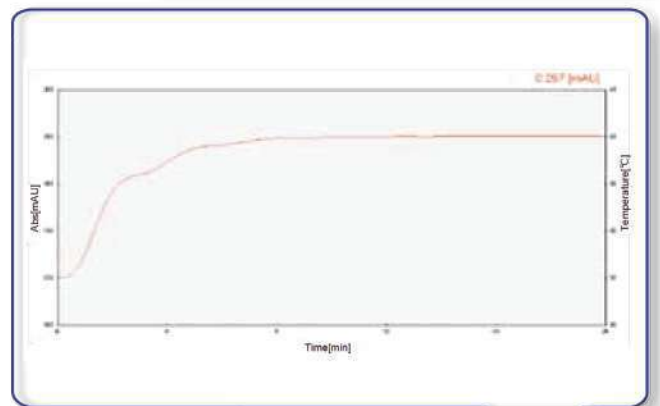
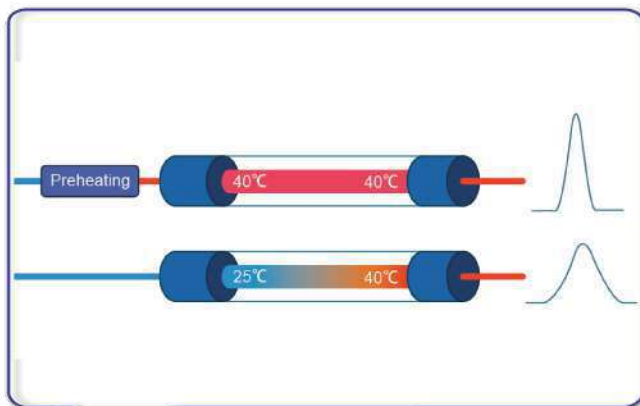
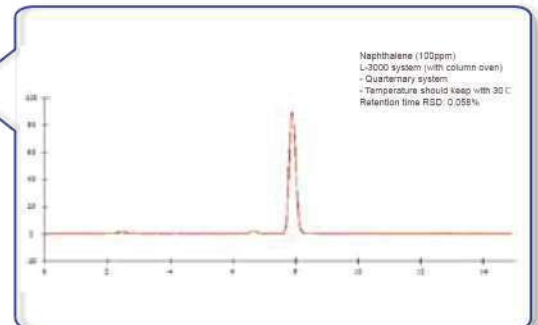

What is the semiconductor temperature control?

Utilized the Peltier reaction of semiconductor material, once the DC go through two different semiconductor material assembly couple, the couple will absorb and release the heat, so it could realized the cooling or heating target. The feature is, there is no any mobile parts and more reliable also.

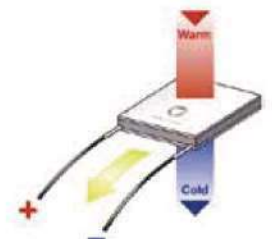



ID 50mm DAC Column

Performance Highlights

The DAC (dynamic axial compression) column adopts latest design by ATL. The piston of column always produces a stable pressure on packing bed which can effectively prevent the collapse and loose of the column bed.

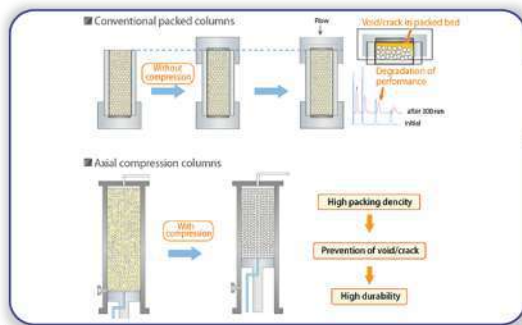

In packing operation of axially compression columns, pressurizing by cylinder followed by loading slurry into columns can create homogenous packed bed. Packed bed pressurized by cylinder realizes high performance columns which are high densely and homogeneously packed. Prevention of voids by constant pressurization also realizes long column life as a result of improvement of durability. (Axial Compression Technology)

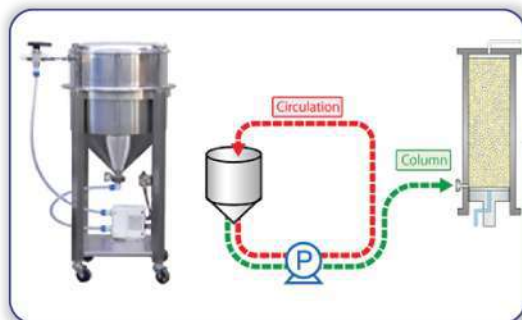

The slurry container provides excellent distribution of packing material and allows for a "homogenous" slurry that can be automatically loaded into the DAC column by simply switching a valve. Throughout the operation from slurry preparation to filling slurry, safety and hygiene can be achieved.

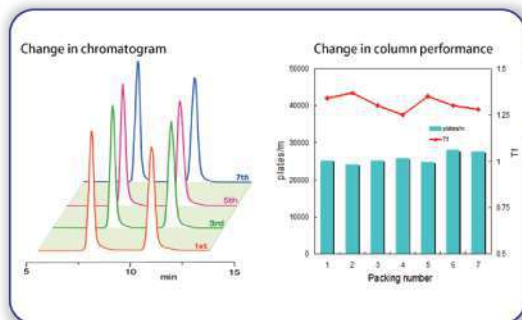

The data on the right hand side shows repacking data obtained by using a 50 mmI.D. DAC column (DAC-50). After 7 times repacking, plates/m and Tf are still as good as the initial state.

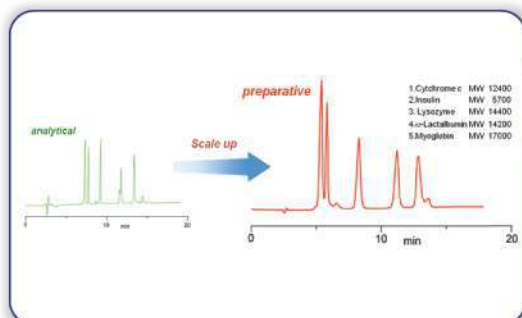

The chromatography on the right hand side are a scale-up example from an analytical 4.6 mmI.D. column to a preparative 50 mmI.D. DAC column. This indicates that the very similar separation pattern of analytical scale is also reproducible at the preparative scale.



ID 800mm DAC Column

Performance Highlights

DAC stands for dynamic axial compression. It combines the preparative column and packing system together, it is very simple to operate. The column can be used online when it is packed well, don't need to take the column down. It prevents mechanical degradation of the particles. Bed compression is maintained constant, independent of swelling and shrinking of the bed, if the solvent conditions are such that particle swelling takes place, then the piston automatically let the bed expand to maintain constant compression.

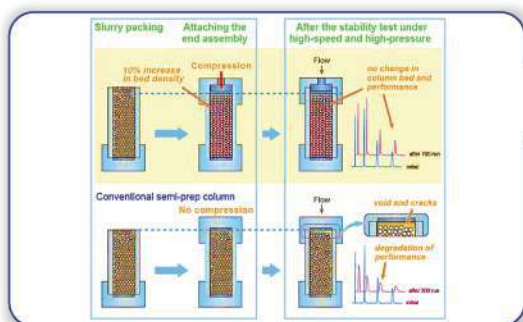

ATL DAC Column have been developed by applying the Axial Compression Technology to semi-prep column. The column bed is compressed adequately by attaching the end assembly newly designed for YMC-Actus. It provides proper bed density (10% higher than conventional columns) and bed uniformity. The combination of technology acquired by long our experience with DAC column, the advanced technique of slurry packing, and new hardware design offers an outstanding durability and efficiency for us.

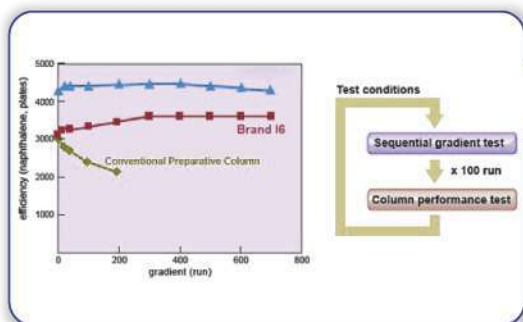

In case of wrong packing conditions, rapid pressure change under the high-speed gradient condition degrades column performance. To examine bed stability, the column performance was evaluated after every 100 runs of the sequential high-speed gradient. ATL offers superior initial column efficiency compared to competitors. Furthermore, its excellent performance is maintained after a long series of gradient test.

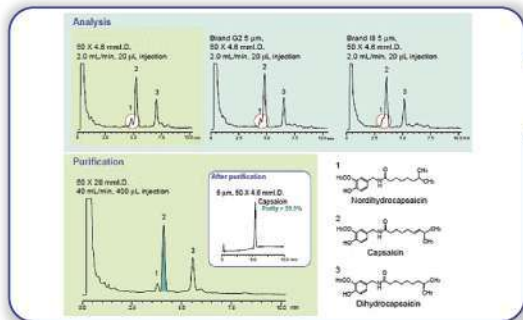

ATL has as high performance as the analytical column, and it is possible to scale up directly from analytical to preparative separation without loss in resolution. ATL Column has superior selectivity for hydrophobic compounds that differ slightly in structure and hydrophobicity. It achieved better resolution between nordihydrocapsaicin (peak 1) and capsaicin (peak 2) than competitors. Target compound was purified with high purity on ATL ID 800 in direct scaling-up.

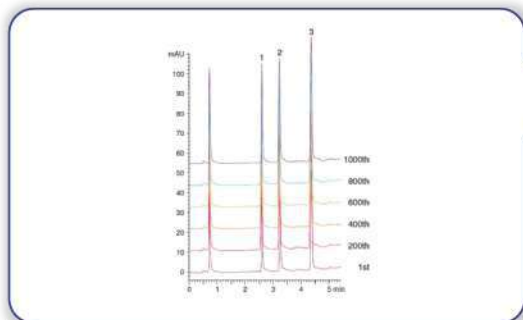

ATL provides outstanding stability and reproducibility in the separation of pharmaceuticals dissolved in 100% DMSO, even after 1000 injections under the fast gradient condition. It is ideal for high-throughput purification in drug discovery.

AnaCHROM[®] Clarity Software (P/N: 103010000994)

Clarity workstation furthers the capability of 3000plus series HPLC system with Analysis solution research and development, instrument control, data acquisition and processing, report generation, and traceable record management with versatile extensibilities.



© Compliance with FDA 21 CFR Part 11/GMP/GLP

AnalCHROM[®] Audit Trail Electronic Signatures

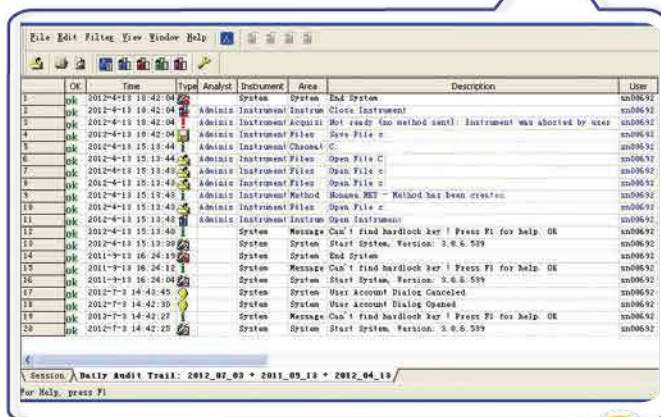
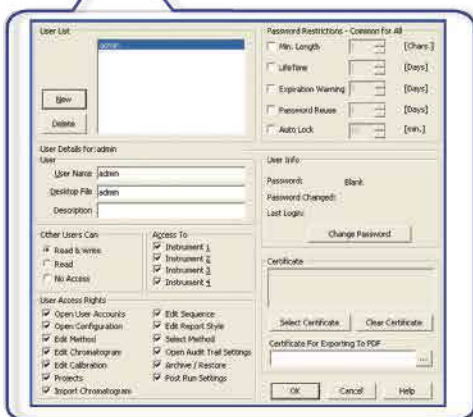
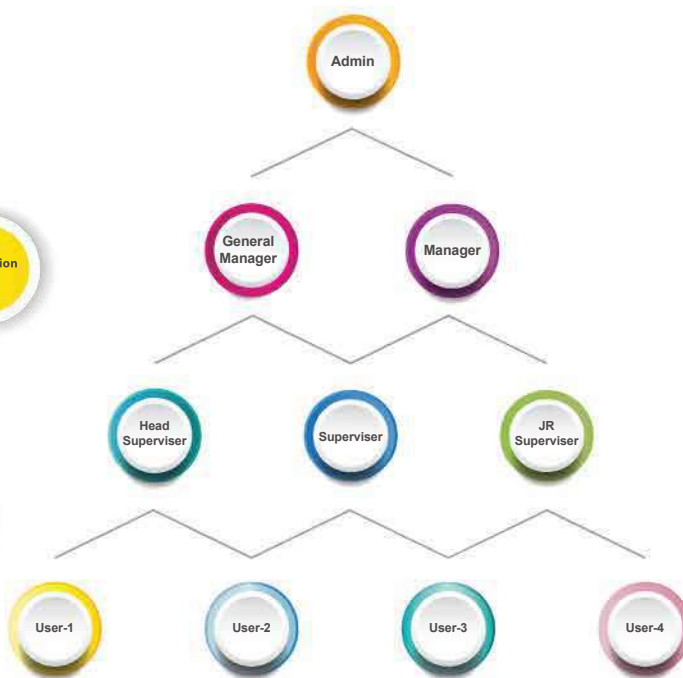
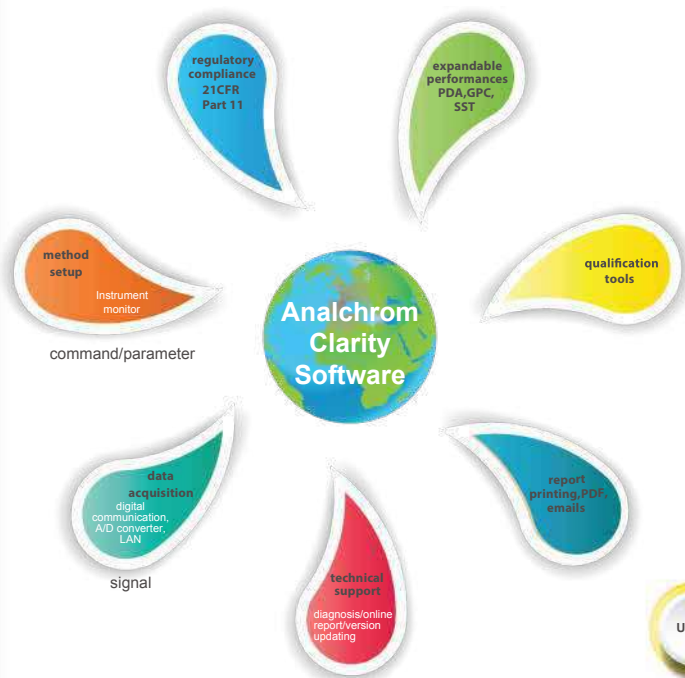

Direct instrument control plus intuitive user interface give user the simplicity of operating the instrument from software.

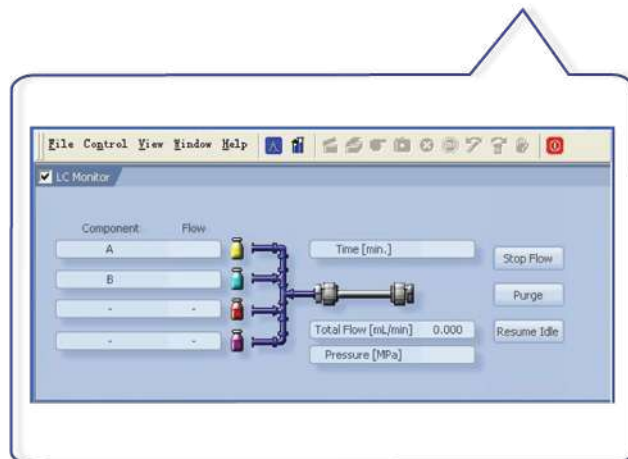
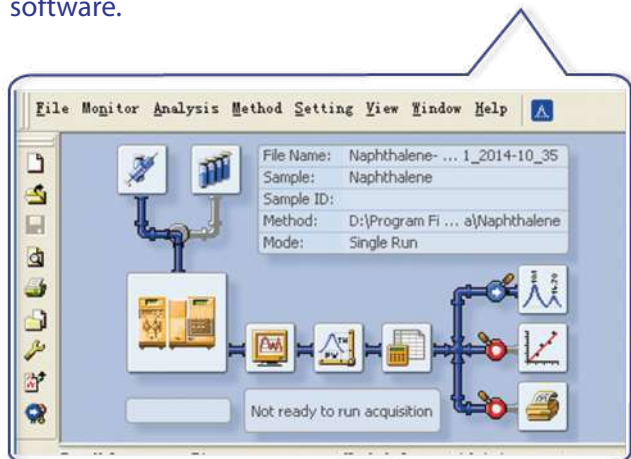

Simple method editing interface and powerful data processing with more than twenty integral functions.

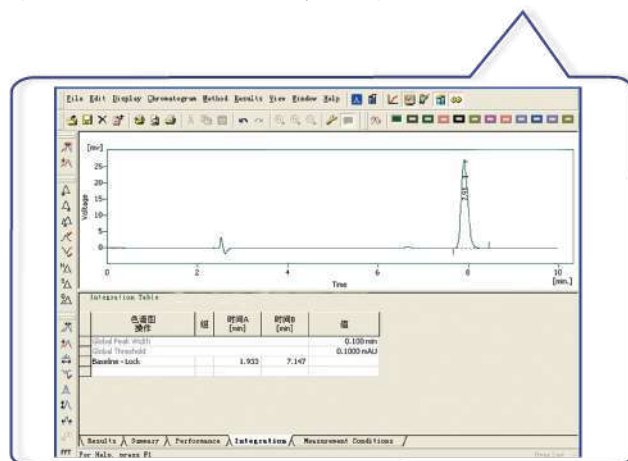
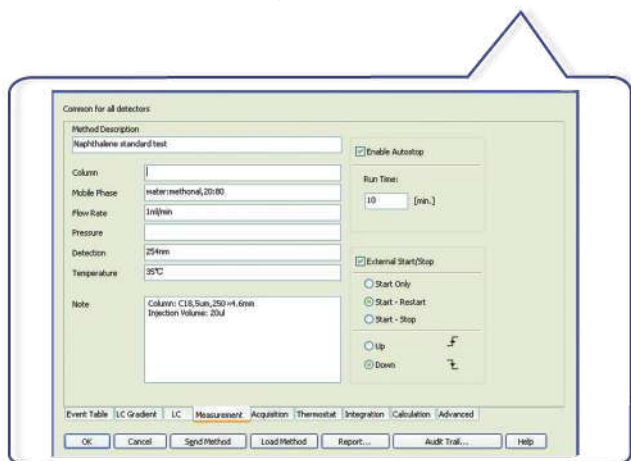

Various calibration procedures and customizable report editor.

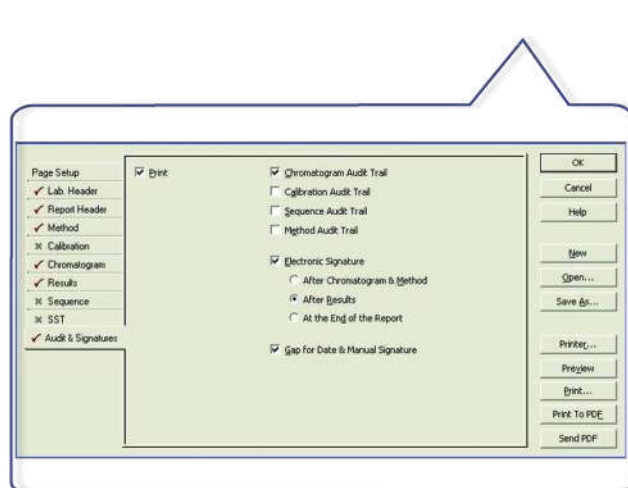
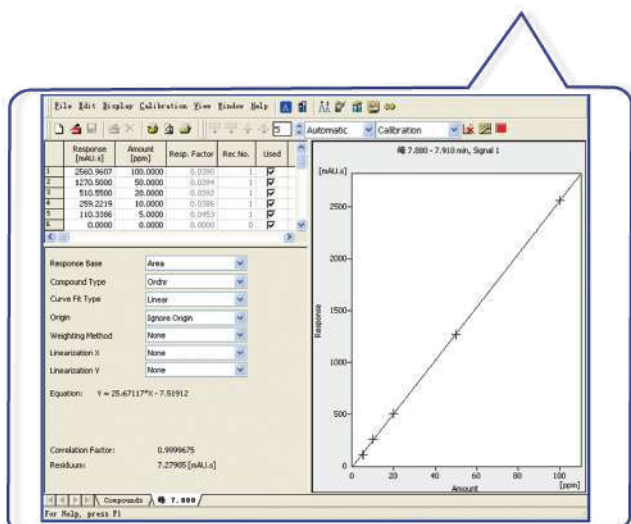



3100 Plus Mass Spectrometer

Performance Highlights

Cost-effective LC-MS solution

LC-MS 3100 Liquid Chromatograph Mass Spectrometer is a commercial LC-MS system which meets the national standards for LC-MS and for determination of chemicals in food and environment. Our Patented heating technology and nebulizer gas technology help increase vaporization efficiency and background noise while increasing sensitivity. Powerful ChemAnalyst LC-MS chemical workstation software simplifies all operation procedures and advanced networking function enables remote control instrument and view test result.

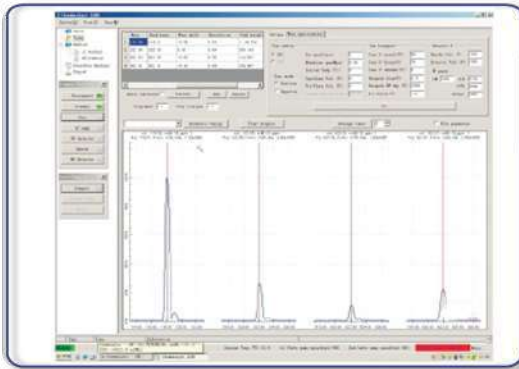

Qualitative analysis- Full scan mode for qualitative analysis of target molecules in the sample Quantitative analysis- Selected ion monitoring mode (SIM mode) for quantitative analysis of target molecule With higher detection ability-SIM mode is used to analyze low concentration or low ionization efficiency samples while Full scan mode is able to analyze higher concentration or high ion efficiency unknown sample The multi-channel acquisition function of LC-MS 3100 enables to analyze more compounds in a single sample scan.

Advanced Software

Power LC-MS chemical workstation software (chemAnalyst) simplifies all operation procedures from tuning to method set, sampling to qualitative and quantitative data analysis. Advanced networking function enables you to remote control instrument and view test results.

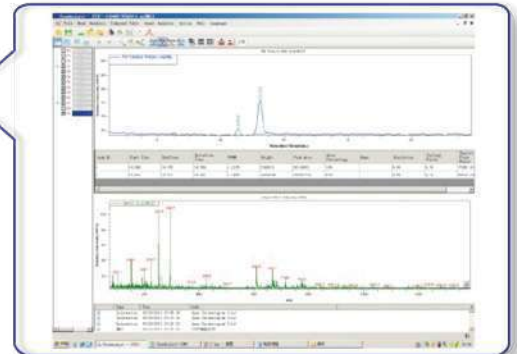

1. Medicine production monitoring

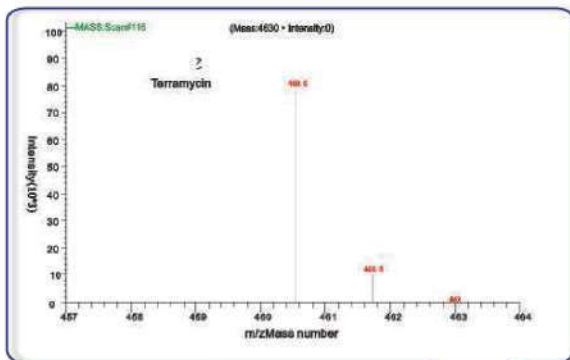

A. Antibiotics

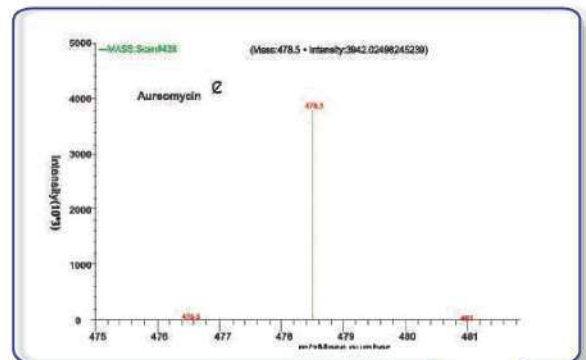

Features

- Quick scan speed (maximum 10,000 amu/s, bar chart)
- Wide scan range (10-1100 amu)
- High detection sensitivity
- Auto calibration and tuning function
- LC high pressure pump, auto sampler, thermostat, UV detector, mass spectrum
- Control and data process are integrated in the software Wireless vacuum chamber.

Performance Highlights



Electrochemical Detector

- Quantify femtogram levels of oxidizable or reducible compound
- Automatic detection parameters configuration
- Four independent controlled channels
- Advanced multi-level digital filtering
- Detection control via USB 2.0/optical/RS-232
- Fluid leakage detection
- Multiple Detection modes: direct current, pulsed amperometric and scanning
- Flow cell convenient position for simple cleaning and assembly
- Stabilized temperature for better accuracy with integral flow cell
- Cell assembly/detection unit enclosed in a faraday cage.

Technical Specification

Working Potential	± 2.00 V
Measurement Range	± (10pA-20uA)
Auto Zero Range	max ±50uA
Manual offset Range	max ±50uA
LCD - Display	display of setting and measurement data
Filter	5Hz - 0.02 Hz 1,2,5 steps
Detector noise level	<750fA with 500 M ohms, 0.47 uF
Cleaing Potential	± 2.00 V
Detay time cleaning	10 - 1500sec
Cleaning Cycle	every 1st to 10th cycle
DC Current	10pA - 1mA in 1-2-5 sequence
Storage capacity for measurement program	0 - 99
Storage capacity for cell-cleaning program	0 - 99
Pulse mode range	10pA - 200 uA in 1,2,5 steps
Filter (cut off) advanced digital filter	0.4 - 0.001 Hz, 1,2,5 steps
Scan mode range	10pA - 200uA (in 1,2,5 steps)
Scan rate	1-50mV/s (in 1,2,5 steps)
Analogram Output	+ 1V per measurement
Signal range	10pA to 500µA
Auto-Zero interface	active low
Input	115-320v, 50-60Hz
Output	+ 10 and -10V (20 bit D/A converter)
Dimensions	260 x 251 x 160 mm
Weight	7.6 kg
Guard cell potential	±200mV



Solvent Organizer	3000plus Binary Solvent Organizer	3000plus Quarternary Solvent Organizer
Online	standard Configuration	
Online Degassing	2-channel	4-channel (480µL/channel)



Delivery Pump	3000plus Isocratic pump (P/N:102010000661)	3000plus Binary pump (P/N:102010000662)	3000plus Quarternary pump (P/N:102010002581)
Online Degassing	None	2-channel	4-channel (480µL/channel)
Delivery Method	Double piston plunger, series/ parallel.		
Flow Rate Range	0.0001mL/min -10.000mL/min (increment 0.001mL/min)		
Flow Rate Accuracy	±0.5% (@1mL/min, water)		
Flow Rate Precision	≤0.025% RSD (@1mL/min, water)(ASTM)		
Max. Pressure	9,000 psi (Standard) 12,000 psi (Optional) 18,000 psi (Optional)		
Pressure Pulsation	≤1% (@1mL/min, water, backpressure 60Mpa)		
Gradient Accuracy	None	+0.5%	
		≤0.2% SD	≤0.2% SD
Composition precision	≤0.15%		
Composition accuracy	±0.5%		
Pump Seal Wash	Automatic, integral, active, recirculating		
Gradient mixing	Active		
pH Range	1 to 12		
Gradient Delay volume	800-1100µL		
Plunger rinsing	Automatic and programmable		
Safety features	Leak sensor, safe leak handling, Leak output signal for shutdown of pumping system. Low voltage in major areas with option to upgrade.		
Internal volume per channel	1.5 mL		
Composition range	Settable range 0-100%		
Compressibility Compensation	User-selectable, based on mobile phase compressibility		



Column Oven	3000plus Column Oven (P/N: 102010000709)
Temperature Range	4°C below ambient to 100°C
Temperature Accuracy	±0.1 °C
Temperature Stability	±0.1 °C
Temperature Precision	±0.1 °C
Column Length	300mm, upto two columns, 50mm guard column
Display	4 digits
Power Consumption	145W
Solvent Condition	pre heating
Column tracking	information management tracks and archives column usage history
Switching valve	Two nine port, eight position



Evaporative Light Scattering Detector- (P/N: 101020003558)	
Light Source	Tungsten / Halogen/LED 470mm
Temperature Range	20-100°C, 0.1°C Increment, feedback accuracy to 0.1°C
Flow Rate	0.1mL/min - 2.5mL/min (standard)
Air Consumption	<3.0L/min
Air Required	>5L/min nitrogen gas or air, 65 Psi
Nebulizer(high flow rate)	100-3000 µl/min
Nebulizer chamber	Thermally controlled, Heater 0-100%, Cooler(on/off)
Gain Setting	0-1000
Sample Rate	upto 80 Points
Optics	Heated Optics Bench
Lamp calibration	Pre aligned assembly
Detector	PMT
Scattering angle	60 Degree
Measurement range	0.1-2000light scattering units full scale
Angle Output	2, LS units nebulizer, drift tube, CHM Gas pressure





UV-VIS Detector	3000plus UV-VIS Detector (P/N: 102010000674)
Measurement range	0.0001-4.0AU
Wavelength	190-800 nm
Light Source	Deuterium lamp, Tungsten lamp
Spectral Width	≤ 6nm
Wavelength Accuracy	±1 nm
Wavelength Precision	0.2 nm
Baseline noise, Single wavelength	≤5.0x10 ⁻⁶ AU
Baseline noise, Dual wavelength	≤35.0x10 ⁻⁶ AU
Drift	≤1x10 ⁻⁴ AU/Hz
Linear Range	≤5% at 2.5AU (ASTM)
Max. Sampling Rate	120 Hz
Flowcell Pressure	1200 PSI
Flowcell light Path	10 mm
Flowcell Volume	12μL
Flowcell design	suitable flow cell
Detection limit	5x10 ⁰ g/mL
Lamp Hour	D2 lamp > 2000hr Lifetime
Repeatability	0.1 nm.
Wetted material	SS, PEEK, Fused silica

Refractive Index Detector	3000plus Refractive Index Detector (P/N: 101020002866)
Flow cell type	3 chamber-type
Measuring method	Deflection type
Refractive Index range	1.00 to 1.75
Measuring range	0.125 to 600μ RIU
Drift	1x 10 ⁻⁷ RIU/h (pure Water, Response : 1.5 sec)
Response	0.1,0.25,0.5,1,1.5,2,3,6 sec
Flow rate(Typical)	0.2 ~3.0mL/min
(Max.)	10mL/min(solvent: pure water)
Auto Zero	Full Auto Zero
Auto Zero Range	All Range
Noise	< ± 1.5x10 ⁻⁹ RIU
Integrator output	DC 0 TO 1 V (Sensitivity) 4m V/ μRIU,16m V/ μRIU)
Cell Volume	2.5 μl
Cell pressure	70 psi
Max .back Pressure	50kpa
IN to Cell	ca .80μL
Internal Volume	cell to Out :ca 600 μL ALL (Cell to Out :ca 690 μL
Recorder output	0 to 10m V/FS
External Output	(1) READY (temperature control) (2) LEAK (3) ERROR (ROM, RAM, PARAMETER,HOME POSITION,OVER-HEAT,OPTI.-BALANCE,INTENSITY)
Temperature Accuracy	± 0.5 °C OFF, 30 to 500 °C (1 °C Step)
Temperature Control	77 °C Temp. fuse (Double Temperature Control)
Communication port	USB
Operational support functions	None
Wetted materials	Stainless steet 316, Teflon, Quartz glass
Valves	purge & recycle





Power Source, Power consumption	AC 100 to 240V +10%, 50/60 Hz, 150VA max.
Dimensions, Weight	W260xD400xH150(mm),ca.12Kg
Linearity Range	≤ 1 n RIU



Diode Array Detector	3000plus Diode Array Detector (P/N: 102010002799)
Diode Array	1024 diodes
Diode width	≤1.2 nm
Wavelength	190 - 800 nm
Light Source	Deuterium lamp & Tungsten lamp
Spectral Resolution	0.6 nm/pixel
Spectral Width	≤1.0nm, 4.8 nm
Wavelength Accuracy	± 1 nm
Wavelength Repeatability	± 0.1 nm
Wavelength Precision	± 0.1 nm
Noise	±0.6x10 ⁻⁵ AU(ASTM)
Drift	<0.9x10 ⁻³ AU/hr
Linear Range	≤5% at 2 AU
Max. Sampling Rate	12 channels, 120 Hz Full spectrum, 120Hz
Data Acquisition	80 Hz
Flowcell Pressure	1740 PSI
Flowcell Light Path	10 mm
Flowcell Volume	13 µL, 2.5µL (semi-micro) with minimum RI effect
Detection Limit	2x10 ⁻⁸ g/mL (naphthalene)
Wavelength Calibration	Mercury peaks and built-in homium oxide filter
Temperature Operating Range	5°C below ambient temp to 50°C (temperature control facility)
Lamp Hour	D2 lamp > 2000hr Lifetime
Rise Time	0.0s - 9.9s
Power	AC 10V / 220V, 50Hz / 60Hz
Consumption	110W
Dimensions	420mm x 280mm x 175mm
Detection	Double Wavelength
GLP function	Date of lamp replacement, number of ignitions, Ignition time, energy and automatic wavelength check etc.
Combination of flow cell path length & volume	0.5µL
Resolution	1.2 nm per photodiode
Digital and Optical mode	3D
Provision	Provision of low noise performance within the operable wavelength range without lamp change

Fluorescence Detector	Fluorescence Detector 3000plus Optical System (P/N: 106829102020)
Monochromators	Holographic concave diffraction grating monochromators for both excitation and emission
Light Source	150W Xe lamp
Mode	Multi-channel/Multi wavelength mode, both Ex and Em
Settable wavelength	Zero order, 200 - 1200 nm Both Ex And Em
Measuring wavelength Range	Zero order, 200 - 1200 nm for both Ex and Em Optional PM tube extends the range up to 900 nm.
Spectral bandwidths	Ex: 18 nm Fixed Ex: 18, 40 nm selectable
Wavelength Accuracy	±2.0 nm
Wavelength Repeatability	±0.2 nm
Wavelength Reproducibility	±0.2 nm
Detectors	Ex: Photodiode Ex: photomultiplier
Facilitate accurate and reproducible integration	Low volume(<13uL), axially illuminated flow cell design





Cell volume	16 µl (standard)
Temperature Operating Range	5 °C, Ambient temp to 50 °C
Temperature Accuracy	+0.5 °C
Pulse Frequency	(20 Hz,) Standard (100 Hz) and HP (300 Hz) High Power
Spectrum Scanning	Permanr Scan Stop / Stop Flow
Data Collection rate	100 Hz
Pressure	2Mpa
Sensitivity	S/N ≥350 for Raman peak of water (Ex=350 nm, time constant=1.5 sec, with standard cell)
Sensitivity range	1, 2, 4, 8, 16, 32, 64, 128, 256,and S.
Gain	x1. x10, x100, x1000
Response	Selected
Power	FAST, STD, SLOW (0.5, 1.5, 5 Sec.)
Digital filter	3, 5, 10, 20, 40 sec
Signal processing	Digital processing by A/D and D/A converters
Output	10mV/Fs for recorder (Polarity change is possible.) 1 V/Fs for integrator marker, leak out
Input	marker, autozero, program reset/ran
Self-diagnostics	memories, DC power supply, Ex. energy, leak in cell, lamp operation time
Time programming	64 steps, 10 files, 0.1 to 999.9 minutes in 0.1 min increments for Ex and Em wavelength,range, gain, autozero, spectral bandwidth, and spectral measurement
Spectral scanning	Ex and Em spectra
Spectral subtraction	Ex and Em spectra
Lamp timer	shows accumulated lamp operation time
Lamp pff timer	settable from 0-99.9 hours (0.1 hour increments)
Temperature compensation	compensates PM tube response for temperature variation



Autosampler	AS-3000plus (P/N: 102010001239)		
Injection modes	Full-loop	Partial loop-fill	µL-pick-up
Cross Contamination	<0.02%		
Injection volume	Programmable from 0 µl-100 µl (increase upto 250µL) 1 µl increments(optional for 10,20,100 µl)		
Injections Volume Accuracy	0.1%		
Injection precision	Full-loop injection	< 0.25% RSD	
	Partial loop-fill	< 0.5% RSD	
	µL-pick-up	< 1.0% RSD	
Sample viscosity	0.1 - 5 cP		
Needle wash Inside and outside needle wash with drying.wash can be programmed between injections and between vials/wells.	1 solvent 5 additional wash solvents		
Injection cycle time	23 seconds		
Valve switching time	60 msec		
Wetted parts	SS316, PTFE, TEFZEL, VESPEL,glass, For Bio-kit option: PEEK and Coalet-steel (needle) instead of SS316		
Carry-over	≤0.005% RSD with standard wash Typically <0.01% with extra wash Vials: 2x 50 (2 mL)		
Sample capacity	2x50 2ml vials(Standard) (optional: 96 well plate up to 200 well plate)		
Minimum sample required	10µl residual		
Needle rinsing	Automatic needle rinsing before and after every injection		
Injection linearity	>0.999		

Pressure limit	6000psi (15000psi sampling valve is optional)
Dimensions	300 x 510 x 360 mm (WxDxH) [™] cool 300 x 575 x 360 mm for ALIAS
Standard features	Auto dilution and auto addition
Weight	19 kg, 21 kg for ALIAS [™] cool
Max load on top cover	65 kg
Power requirements	95 - 240 Volt AC ± 10%; 50-60 Hz, 200 VA
Sound pressure level	LeAq < 70 dB
Working temperature	4° - 60°C (0.1°C increments)
Temperature Accuracy	±0.5°C
Storage temperature	-25°C to -60°C
Humidity	20 - 80% RH

Mass Range	10-1500 amu
Mass accuracy	±0.20 amu (mass calibration range of scan mode)
Mass axis stability	±0.2amu/12h (under constant temp. of ± 2°C)
Scan rate : standard mode	1000 amu/s, fast scan mode: 10000 amu/s
Resolution	unit resolution (FWHM < 0.7amu)
SIM signal to noise ratio	ESI, 200 ul/min, SIM
Peak area Repeatability	RSD 4.6%/0
Retention time repeatability	RSD
LCMS MS Mass Spectrometer	Optional

LCMS-MS MASS SPECTROMETER



Dynamic Axial Compression Columns



DAC Column	ID50mm DAC column
Dimensions	500mm×500mm×1900mm
Weight	100kg
Inner diameter	50mm
Total column length	500mm
Max. bed height	300mm (NP 0.3kg packing material; RP 0.39kg packing material)!
Filter	Material: 316L Pore size: 3~5μm
Distributor	Two, in piston and column bottom, Material: 316L Distribution mode: Divergent
High pressure seal	Material: PTFE+316L
Design pressure	10Mpa
Operating Temperature	5~60°C
Control Panel	air pressure gauge, oil gauge, regulating valve, Emergency stop switch, Change direction valve, shut-off valve.
Air source	≥6bar, output ≥0.5m ³ /min
Column tube material	316L
Column bracket material	304
Roughness	Inner surface Ra ≤ 0.4μm, outer surface Ra < 1.6μm
Inlet diameter	1/16"
Outlet diameter	1/16"
Air inlet diameter	Φ8



DAC Column	ID800mm DAC column
Dimensions	550mm×600mm×2200mm
Weight	200kg
Inner diameter	80mm
Total column length	650mm
Max. bed height	300mm" NP 0.75kg packing material; RP 0.98kg packing material)!
Filter	Material: 316L Pore size: 3~5μm
Distributor	Two, in piston and column bottom, Material: 316L Distribution mode: Divergent
High pressure seal	Material: PTFE+316L
Design pressure	10Mpa
Operating Temperature	5~60℃
Control Panel	air pressure gauge, oil gauge, regulating valve, Emergency stop switch, Change direction valve, shut"off valve.
Air source	≥6bar, output≥0.8m ³ /min
Column tube material	316L
Column bracket material	304
Roughness	Inner surface Ra≤0.4μm, outer surface Ra<1.6μm
Inlet diameter	1/8"
Outlet diameter	1/8"
Air inlet diameter	Φ8

Dynamic Axial Compression Columns



Application and Solutions

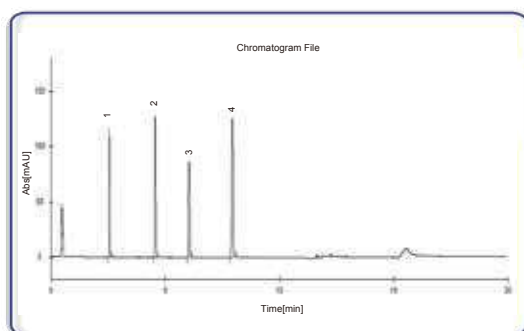

Determine the content of soybean isoflavones in Soybean Isoflavone Soft Capsule by ATL 3000 HPLC system with core-shell column

Soybean isoflavones are a class of secondary metabolites formed in the growth of soybean. They are extracted from plant, similar structure with female hormone, so soybean isoflavones also called phytoestrogen. Soybean isoflavones can improve skin condition and osteoporosis, relieve the symptoms of menopause syndrome.

Chromatographic column: Manufacturer A C18(50mm*4.6mm*2.6um)
Mobile phase: Phosphoric acid solution (pH=3.0) / Acetonitrile; gradient elution
Flow rate: 1.0mL/min
Column temperature: room temperature
Detection wavelength: 260nm
Injection volume: 5μL

Pharmaceutical Analysis

Environment Protection

Content determination of phenols compounds by HPLC

Phenols pollution in environment field means that phenols compounds pollute water. Waste water with phenols is one of the greatest dangerous, and most widely polluted industry waste water. phenols compounds were determined by using ATL 3000 HPLC system. The results show that the method is accurate and sensitive.

Chromatographic column: ATL compass C18(250mm*4.6mm*5μm)
Mobile phase: Water/Acetonitrile; gradient elution
Flow rate: 1.0mL/min
Column temperature: 40C
Detection wavelength: 223nm
Injection volume: 5μL

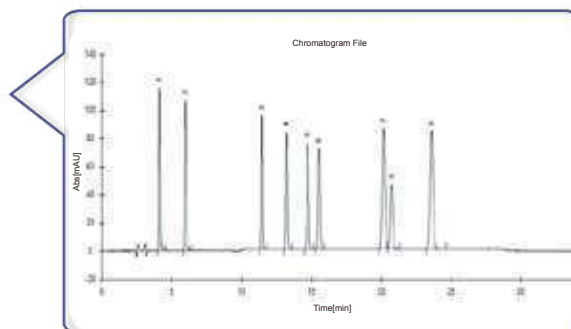

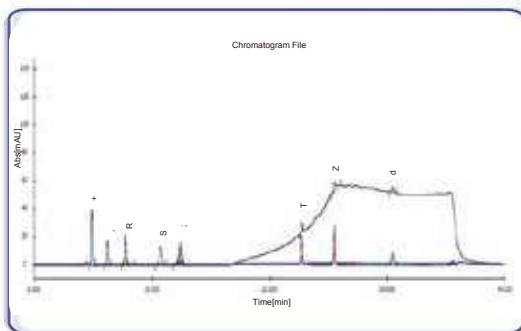

Simultaneously determining the content of 8 kinds of organic acids and Vitamins in fruit by using HPLC-DAD

Organic acids and vitamins are very important dry matter in fruits. They usually decide the special taste of fruits and play an important role in food science and nutriology field. The new method can simultaneously determine organic acids and vitamins in fruits by using HPLC-DAD.

Chromatographic column: ATL Compass C18(2) (250mm*4.6mm*5µm)
Mobile phase: Water/Acetonitrile; gradient elution
Flow rate: 0.6mL/min
Column temperature: 30C
Injection volume: 10µL

Agriculture

Simultaneously determining the content of 4 kinds of sulfa-drugs in fodder by using HPLC-DAD

Sulfa-drugs are a class of chemical medicine for disease prevention and treatment of bacterial infections. If take sulfa-drugs standard exceeding livestock products as food for a long time, it might lead to the damage of hematopoietic system, agranulocytosis and so on problems. So that the application limit of sulfonamides in livestock and poultry raise up and play an important role in food safety field. In this paper, an accurate and sensitive method was established to determine the content of 4 kinds of sulfa-drugs in feed by using HPLC-DAD.

Chromatographic column: ATL Compass C18(250mm*4.6mm*5µm)
Mobile phase: Water/Acetonitrile (75/25)
Flow rate: 1.0mL/min
Column temperature: 40C
Injection volume: 5µL

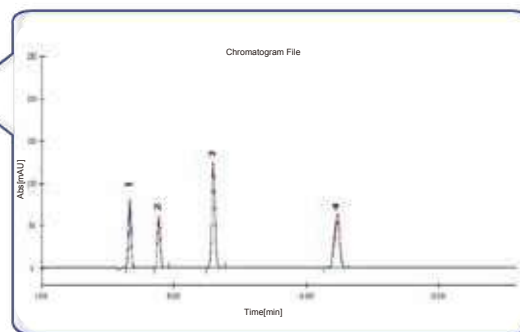

Chemical

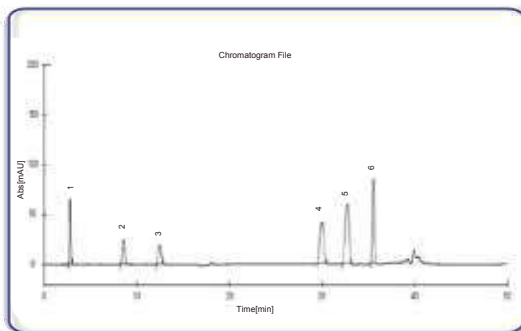

Simultaneously determining the content of 6 kinds of UV absorbers in cosmetics

UV absorbers in cosmetics can reduce or absorb the ultraviolet rays, protect skin. Excess ultraviolet radiation will irritate skin and cause skin sensibility. The application of UV absorbers is managed and controlled strictly. In this paper, a new method is developed to determining the content of 6 kinds of UV absorbers in cosmetics.

Chromatographic column: Manufacturer A C18(250mm*4.6mm*5µm)
Mobile phase: A: MeOH/Tetramethylene oxide (250/450);
B: Water/Perchloric acid (300/0.1); gradient elution
Flow rate: 1.0mL/min
Column temperature: 30C
Detection wavelength: 311nm
Injection volume: 10µL

Antibiotics

Determining the content of terramycin, doxycycline, tetracycline and auromycin by HPLC

In the livestock farming field, all kinds of antibiotics are used for treatment of livestock disease. Tetracycline antibiotics are widely adopt based on its antibacterial effect and cheap price. Tetracycline antibiotics mainly include terramycin, doxycycline, tetracycline and auromycin.

Chromatographic column: Manufacturer A C18(250mm*4.6mm*5µm)
Mobile phase: MeOH/Acetonitrile/0.01mol/L Citric acid solution (12/18/70)
Flow rate: 0.8mL/min
Column temperature: 30C
Detection wavelength: 360nm
Injection volume: 50µL

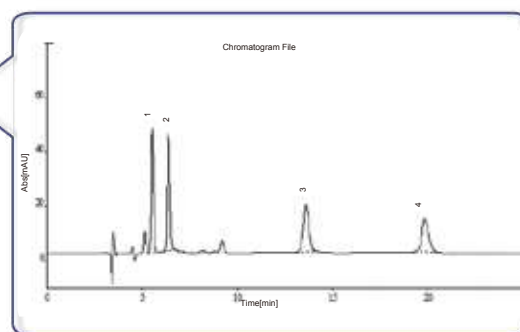



Customer Service

01

Installation

ATL provide installation service with instrument working principle introduction, standard operation procedures, daily maintenance and application developing.

ATL has a professional service team, and build up the maintenance record via the clients information system, we also arrange periodicity visiting service and preventive suggestion.

After Sale Service

02

03

Regulation Compliance

ATL provide the compliance service for HPLC system, including the IQ, OQ, PQ and so on. We can also provide the related training course to match up with the inspection request.

A cross-field application team covering pharmaceutical analysis, food safety, Bioscience and environment field is ready to support. They are focus on solving the application problem raised from client, and will provide the integrated solutions.

Application Support

04

05

Multiple Training

ATL provide abundant online and offline standard training course. And could provide pertinence training course with client application and will enhance the skill of client.

ATL provide 360 degree, proactive service support. Our technical team would like to provide you the technical and maintenance support with fast reaction and reasonable suggestion. Field service engineer team is ready at any time for emergency issues.

Comprehensive Service

06

Spares & Consumables / Columns / Source Lamps / Pre-Installation Requirements

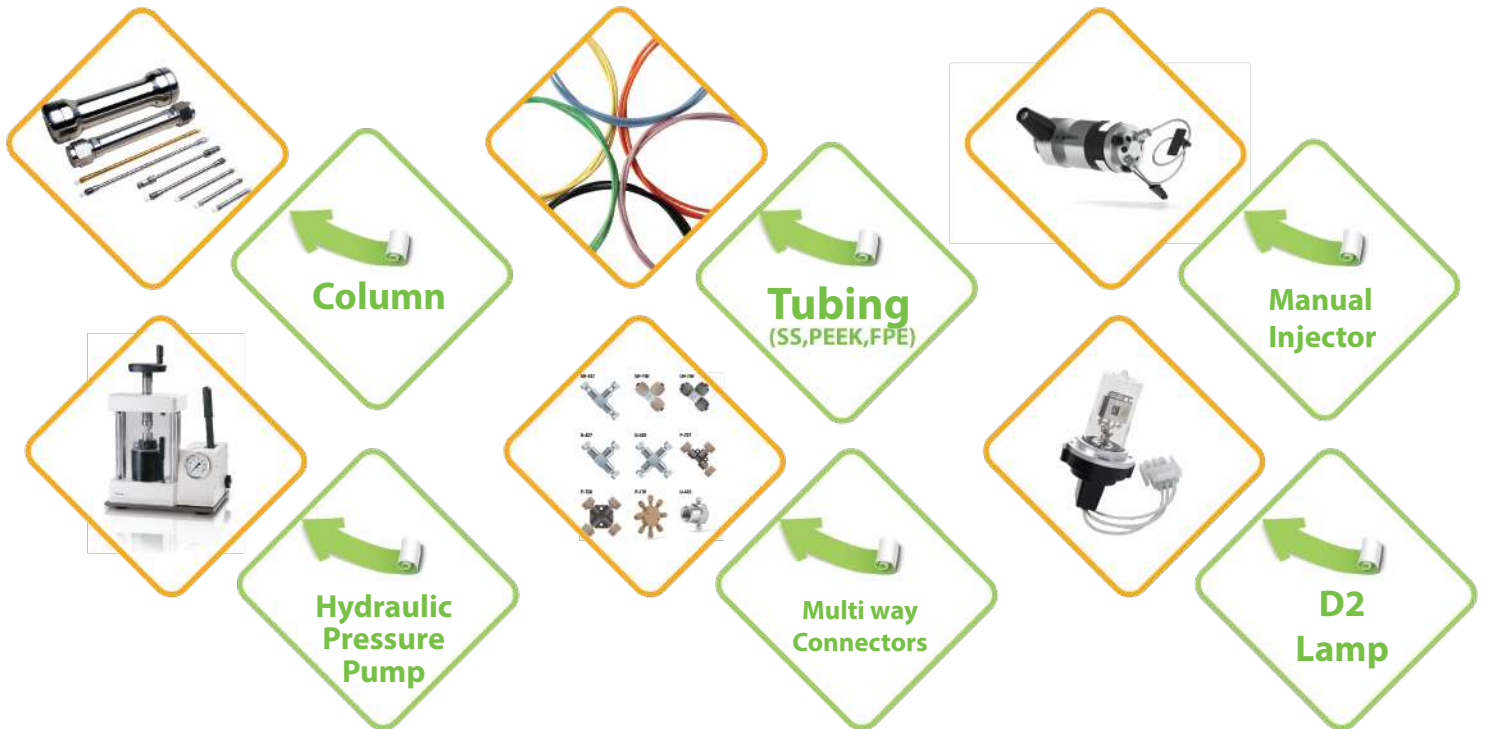

We offer all the Consumables / Reagents Quality / Control Standards / Calibration Standards / Validation Standards required for running the analyzers like HPLC, SPECTROPHOTOMETER, FTIR, HEMATOLOGY ANALYZER, BIO-CHEMISTRY ANALYZERS (Clinical Chemistry Analyzers). We also manufacture reagents for Hematology and Bio Chemistry, Urine Analysis.



UHPLC Consumables like Check Valves Plunger, plunger Seals Columns (Analytical And Prep), pulse Damper, Mixer PEEK Nuts, SS Male, Nuts, Solvent Reservoir Filter, Septas, Vials, Rotor Seal, Stator Face Assy, Loops, Syringes, Bearings, O-Rings, Line Filters for any make of HPLC system. Flow Splitters, Pulse dampers, Multi Purpose HPLC Pumps (Isocratic & Gradient) & Manual Injectors CHIRAL, Preparative, Analytical Capillary HPLC Columns and guard columns, GPC Columns, CombiChem and Amino Acid, Microbore HPLC Columns, BULK Materials for Columns, frits and Hardware for Columns. Source Lamps for all Analytical Instruments such as D2, Halogen, Xenon, Tungsten, mercury vapors hollow cathode lamps etc.

HPLC Servicing, Validation, Trainings and Preventive Maintenance :

HPLC Servicing :HPLC Servicing : We have team of service engineers who can attend to any make of HPLC promptly @the most affordable cost.

Trainings :We also take up preventive Maintenance to reduce downtime of HPLC's Trainings.

AMC's/CMC :AMC's/CMC :We offer user training both in-House and at customer sites on HPLC principles, operations, trouble-shooting.

Validations :Validations :We have protocols for carrying out periodic Validations as per GLP/GMP/USFDA norms.

Instruments :Instruments :We offer instruments/Renting Services Modules like pumps,detector etc. on Rent.



About Analytical Technologies

Analytical Technologies is synonymous for offering technologies for doing analysis and is the Fastest Growing Global Brand having presence in at least 96 countries across the global. Analytical Technologies Limited is an ISO:9001 Certified Company engaged in Designing, Manufacturing, Marketing & providing Services for the Analytical, Chromatography, Spectroscopy, Bio Technology, Bio Medical, Clinical Diagnostics, Material Science & General Laboratory Instrumentation. Analytical Technologies, India has across the Country operations with at least 4 Regional Offices, 6 Branch Offices & Service Centers. Distributors & Channel partners worldwide.

Our Products & Technologies



Regulatory compliances



Corporate Social Responsibility

Analytical Foundation is a nonprofit organization (NGO) found for the purpose of:



Analytical
Foundation

1. Research & Innovation Scientist's awards/QC Professional Award : Quality life is possible by innovation only and the innovation is possible by research only, hence ANALYTICAL FOUNDATION is committed to identify such personalities for their contributions across various field of Science and Technology and awarding them yearly. To participate for award, send us your details of research / testing / publication at Info@analyticalfoundation.org

2. Improving quality of life by offering YOGA Training courses, Work shops/Seminars etc.

3. ANALYTICAL FOUNDATION aims to DETOXYFY human minds,souls and body by means of yoga, Meditation, Ayurveda, Health Care, Awards, Media, Events, Camps etc.

Reach us @



HPLC Solutions MultipleLabs Analytical Bio-Med Analytical Distributors Analytical Foundation (Trust)

Corporate & Regd. Office:
Analytical House, # E67 & E68,
Ravi Park, Vasna Road, Baroda,
Gujarat 390 015. INDIA

T: +91 265 2253620
+91 265 2252839
+91 265 2252370
F: +91 265 2254395

E: info@hplctechnologies.com
info@multiplelabs.com
info@analyticalgroup.net
info@analyticalbiomed.com

W. www.analyticalgroup.net
www.hplctechnologies.com
www.multiplelabs.com
www.ais-india.com

Sales & Support Offices:
across the country :
Distributors & Channel
partners World Wide

Note : Company reserves rights to add/delete/modify the contents / technical specifications of the catalogue without prior notice.